

High Temperature Ball Valves

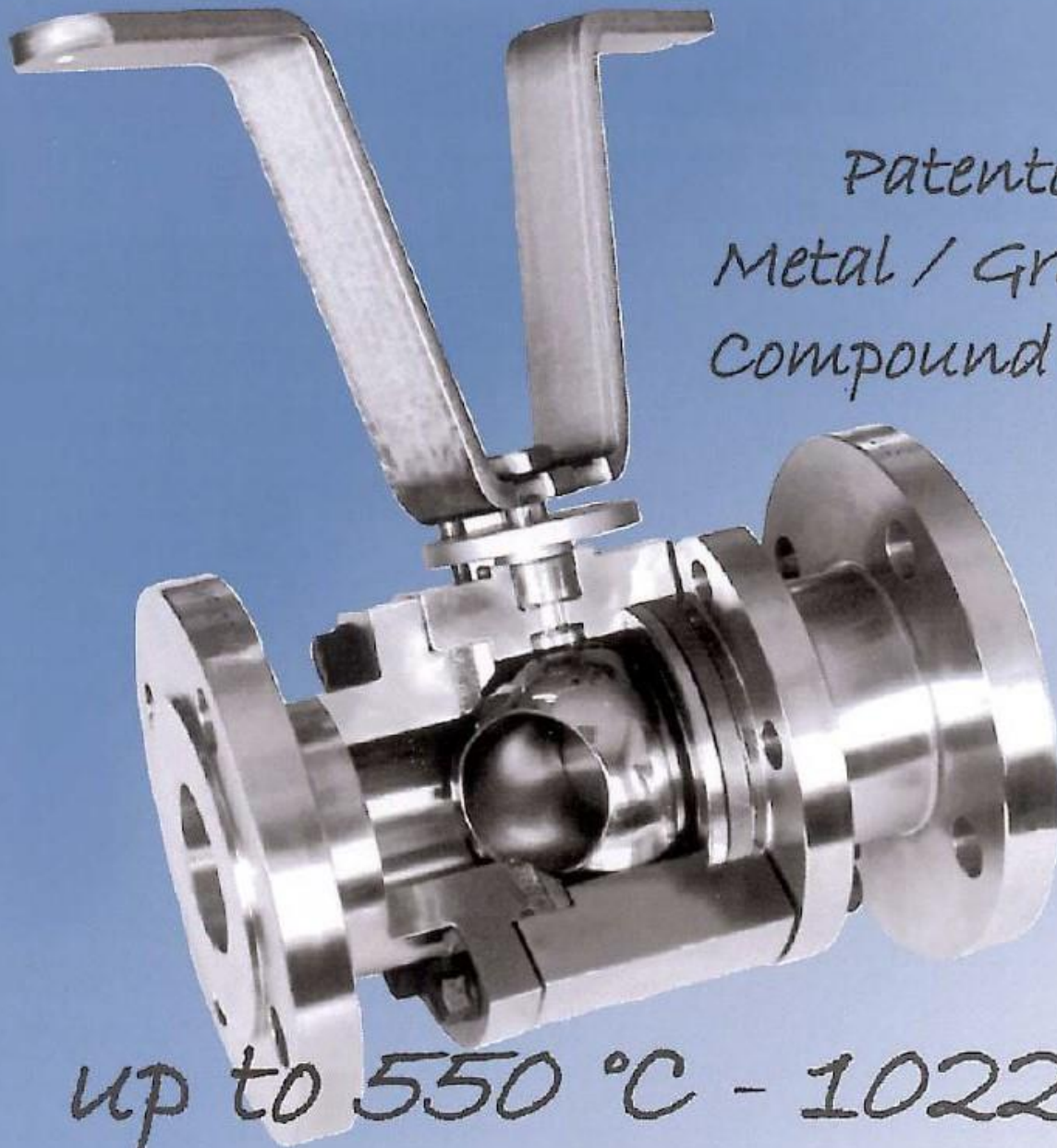

MVA GmbH • Mess- und Verfahrenstechnik
Lochhamer Schlag 6 • D-82166 Gräfelfing
Fon: +49/89-85 83 69-0 • Fax: +49/89-85 83 69-70
info@mva-messvt.de • www.mva-messvt.de



*Patented
Metal / Graphite
Compound Seats*

up to 550 °C - 1022 °F

HTB Ball Valves

The competence for components

Carbon Steel – Stainless Steel
Type HTB, for High Temperature
Rating DIN 2401 PN 40, PN 63 and PN 100
Rating ASME B16.34 Class 300 and 600, full rated
Size DN 15 to DN 100 - ½" to 4"

- This Valve is ONE WAY Valve. Do ensure that the flow direction is the same showed by the arrow on the body.
- Temperature for continuous service up to 550 °C (1022 °F).
- Size: ½" to 4"
- Design Standards: ASME B16-34, B16-5
B16-11, B16-25
MSS SP 72, BS 5351
DIN 2401, DIN 3239
- Fire Safe: API 6FA and BS 6775 certified
- TA LUFT certified
- Split body, three piece
- Floating Ball
- Body Seat: Patented Metal / Graphite Compound
- Packing: Adjustable Graphite Long Life Packing
- Gland: Flanged Type - One Piece bushed
- Stem: Anti blow-out
- Antistatic Device: Design is intrinsically Antistatic
- Torque: Low Torque due to Special Packing, Material and Design
- Every valve, even if already installed, can be completed with an actuator.
Valve actuator attachment according to ISO 5211
- Connections:
 - Threaded NPT to ANSI B1.20.1
 - SW to ANSI B16.11
 - BW to ANSI B16.25
 - BW to DIN 3239
- Flanged:
 - According to European Standards (UNI, DIN, AFNOR, etc.) PN 40
Flanges are supplied raised faced to UNI 2229, drilled, Face to face dimension (A) to DIN 3202-F1
 - According to European Standards (UNI, DIN, AFNOR, etc.) PN 63 and PN 100
Flanges are supplied raised faced to UNI 2229, drilled, Face to face dimension (A) to DIN 3202-F2
 - According to American Standard ASME B16.34 Class 300
Flanges are supplied R.F. drilled to ASME B16.5
Face to face dimension (A) to ASME B16.10
 - According to American Standard ASME B16.34 Class 600
Flanges are supplied R.F. drilled to ASME B16.5
Face to face dimension (A) to ASME B16.10

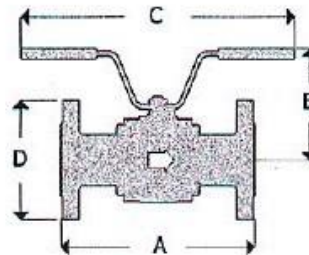

Fig. 941

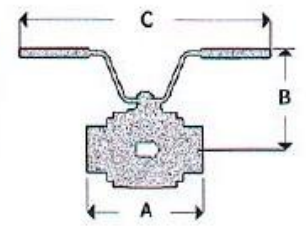

Fig. 942

Ball Valves type HTB - Full Bore

DN	Dimension		Threaded or SW or BW		Flanged DIN PN 40			Flanged DIN PN 63			Flanged DIN PN 100			Flanged ASME 300			Flanged ASME 600			
	B	C	A	Weight	A	D	Weight	A	D	Weight	A	D	Weight	A	D	Weight	A	D	Weight	
	mm	mm	mm	kg	mm	mm	kg	mm	mm	kg	mm	mm	kg	mm	mm	kg	mm	mm	kg	
½"	15	110	180	90	2,5	130	95	3,5	210	105	5	210	105	5	140	95	4,3	165	95	4,5
¾"	20	140	210	100	3,2	150	105	4,7	230	130	6,7	230	130	6,7	152	117	5,4	191	117	6
1"	25	164	270	110	5,5	160	115	7	230	140	8,1	230	140	8,1	165	124	7	216	124	7,8
1.½"	30	215	350	140	7,6	180	140	11,6	260	155	14,4	260	155	14,4	178	133	10,5	229	133	11,4
1.¾"	40	220	350	150	10,6	200	150	15,5	260	170	20,1	260	170	22,4	191	155	15,0	241	155	17,3
2"	50	230	350	170	14,7	230	165	22,5	300	180	24,2	300	195	26,5	216	165	21,9	292	165	23,6
2.½"	65	235	500	210	29	290	185	43,7	340	205	47,2	340	220	50,6	241	190	43,7	330	190	46,0
3"	80	250	500	305	35	310	200	50,0	380	215	53,8	380	230	57,5	283	209	50,0	356	209	52,9

ASME Class 150 may be supplied on request. Please note that FACE TO FACE (Dimension A) for ASME 150 are as per ASME 300 - ▲ for BW type only

Ball Valves type HTB - Reduced Bore

DN	Dimension		Threaded or SW or BW		Flanged DIN PN 40			Flanged DIN PN 63			Flanged DIN PN 100			Flanged ASME 300			Flanged ASME 600			
	B	C	A	Weight	A	D	Weight	A	D	Weight	A	D	Weight	A	D	Weight	A	D	Weight	
	mm	mm	mm	kg	mm	mm	kg	mm	mm	kg	mm	mm	kg	mm	mm	kg	mm	mm	kg	
¾"	20	110	180	90	2,9	150	105	3,9	230	130	5,3	230	130	5,3	152	117	4,6	191	117	4,8
1"	25	140	210	100	4	160	115	5,5	230	140	7,5	230	140	7,5	165	124	5,8	216	124	6,6
1.½"	32	164	270	110	6	180	140	7,5	260	155	8,8	260	155	8,8	178	133	8,5	229	133	9,5
1.¾"	40	215	350	140	8,1	200	150	12	260	170	14,5	260	170	14,5	191	155	11,5	241	155	13,5
2"	50	220	350	150	11,2	230	165	16	300	180	20,7	300	195	23,0	216	165	17,3	292	165	19,6
2.½"	65	230	350	191	17	290	185	24	340	205	25,9	340	220	28,8	241	190	25,3	330	190	27,6
3"	80	235	500	210	31	310	200	45	380	215	48,9	380	230	52,3	283	209	47,2	356	209	50,6
4"	100	250	500	305	38	350	235	52	430	250	55,8	430	265	59,8	305	254	54,1	432	273	57,5

ASME Class 150 may be supplied on request. Please note that FACE TO FACE (Dimension A) for ASME 150 are as per ASME 300 - ▲ for BW type only

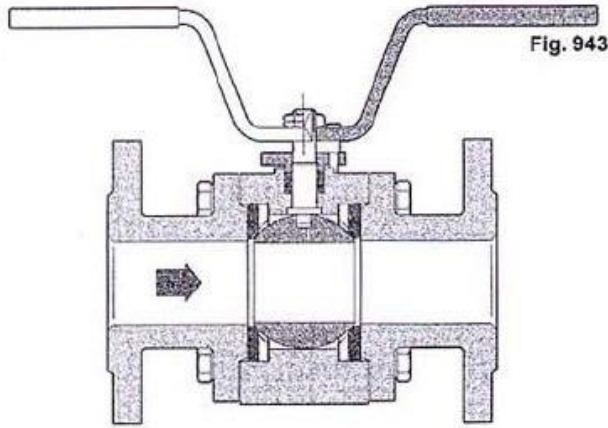

Fig. 943

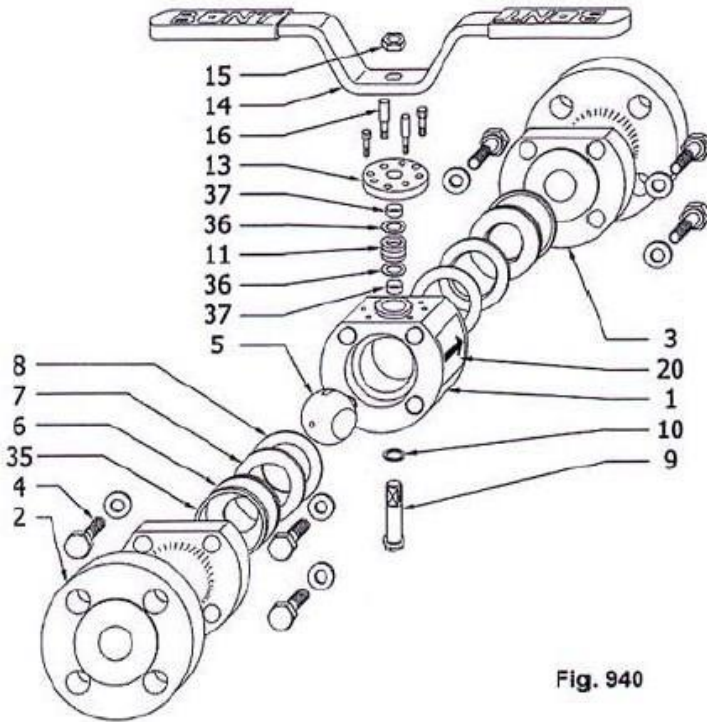

Fig. 940

Material Schedule	Material used for	
	Body and End connections	Ball and stem
52	ASTM A105	ASTM A182 F316 + S.H.
63	ASTM A182 F316	ASTM A182 F316 + S.H.

MVA HTB ball valve is a valve for high temperature. The primary innovation of this valve resides in the original seat design. It is not the usual metal seat but an original semi-soft seat.

The main characteristics of HTB ball valves are the following:

- suitable for any kind of fluid compatible with graphite. Particularly suitable for application on water/steam even with high pressure drop.
- Nearly indefinite bubble tight seat tightness throughout the full range of operations.
- High resistance to erosion.
- Very effective in the handling of abrasive containing fluid and any dirty media. The alternating metal-graphite layers of the seat sweep the ball surface cleaning it during every open-close operation.
- Packing characteristics avoids any measurable fugitive emission in the environment.
- Maintenance Free. However if, for any reason, maintenance is ever required, the seat replacement is simple and inexpensive thanks to the low cost of the seat rings and their ability to auto-adapt to the ball. Thus eliminating the need to replace the complete ball and seat assembly as it is normally done in metal seated ball valves.
- FIRE TEST - Certificate No. MLN9901225/1-2. It is important to remark that the breakaway torque difference before and after fire test is negligible.
- TA LUFT TEST - Certificate No. 86T409. To be remarked:
 - No need of packing retightening during tests, although allowed.
 - Checked leakages of some order of magnitude inferior to the admitted ones.
 - Test has been performed at temperature of 427 °C (800 °F), limit imposed by the valve body material.

More tests at temperature of 550 °C, with different body material, have been performed with satisfactory results.

Item	Part	Item	Part
1	Body	11	Packing
2	End Connection Inlet	13	Gland Flange
3	End Connection Outlet	14	Handle
4	Bolt	15	Handle Nut
5	Ball	16	Gland Bolt and Stop Pin
6	Seat	20	Name Plate
7	Cushion Plate	35	Autoseal Ring *
8	Cushion Joint	36	Spacer Ring ●
9	Stem	37	Stem Ring ●
10	Bottom Stem Joint		

* only: on Full Bore \geq DN 32 and \geq 1/4"
 on Reduced Bore \geq DN 40 and \geq 1.1/2"
 ● only: on Full Bore \geq DN 20 and \geq 3/4"
 on Reduced Bore \geq DN 25 and \geq 1"

RATING for the Materials mentioned in this Bulletin

Max operating TEMPERATURE to DIN	Max. Operating PRESSURE to DIN 2401					
	Class PN 40 Mater. Sched. 52	Class PN 40 Mater. Sched. 63	Class PN 63 Mater. Sched. 52	Class PN 63 Mater. Sched. 63	Class PN 100 Mater. Sched. 52	Class PN 100 Mater. Sched. 63
	bar	bar	bar	bar	bar	bar
-10 + 20	40	40	63	63	100	100
120	40	40	63	63	100	100
200	35	35	50	50	80	80
250	32	32	45	45	70	70
300	28	28	40	40	60	60
350	24	24	36	36	56	56
400	21	21	32	32	50	50
425	-	-	-	-	-	-
450	-	-	-	-	-	-
500	-	-	-	-	-	-

Max operating TEMPERATURE to ASME and API	Max. Operating PRESSURE to ASME					
	Class 150 Mater. Sched. 52	Class 150 Mater. Sched. 63	Class 300 Mater. Sched. 52	Class 300 Mater. Sched. 63	Class 600 Mater. Sched. 52	Class 600 Mater. Sched. 63
	bar	bar	bar	bar		
-29 + 38	19.6	19.0	51.1	49.6	102.1	99.3
100	17.7	16.2	46.4	42.2	92.8	84.5
200	14.0	13.7	43.8	35.7	90.5	71.2
250	12.1	12.1	41.7	33.4	83.4	66.7
300	10.2	10.2	38.7	31.6	77.5	63.1
350	8.4	8.4	37.0	30.4	73.9	63.1
400	6.5	6.5	34.5	29.3	69.0	58.9
425	5.6	5.6	28.8	29.0	57.5	58.3
450	4.7	4.6	20.0	29.0	40.1	57.7
500	2.8	2.8	8.8	27.3	17.6	54.8

Attachment to Bracket for Actuator

Attachment to Bracket for Actuator according to ISO 5211

Valve DN		Flange ISO 5211	Ød2 f8	Ød3	Ød4 x e	h	A	B	C	D
Full Bore	Red. Bore									
½"	¾"	F03	25	36	M5X6.5	2	Ø9.8	6	4.5	10.5
¾"	1"	F03	25	36	M5x8	3	M12	7.4	10	23.0
1"	1.¼"	F04	30	42	M5x8	3	M12	7.4	14.5	30.5
1.¼"	1.½"	F05	35	50	M6x8	3	M14	8.8	16	35
1.½"	2"	F05	35	50	M6x8	3	M14	8.8	16	35
2"	2.½"	F05	35	50	M6x8	3	M14	8.8	16	35
2.½"	3"	F07	55	70	M8x8	3	M24	18	27	61
3"	4"	F07	55	70	M8x8	3	M24	18	27	61

Relevant Break-away Torque will be communicated on request, based on the process condition.

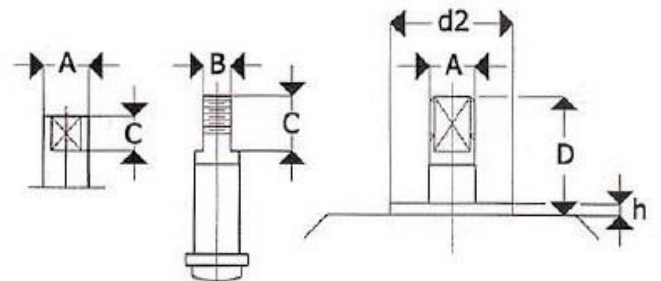
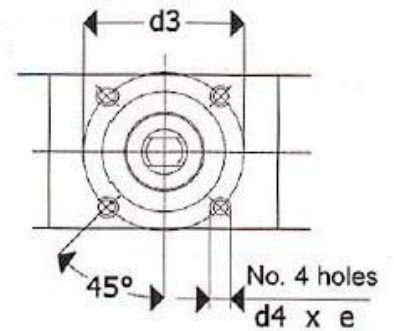

Fig. 944



Option for insulating service

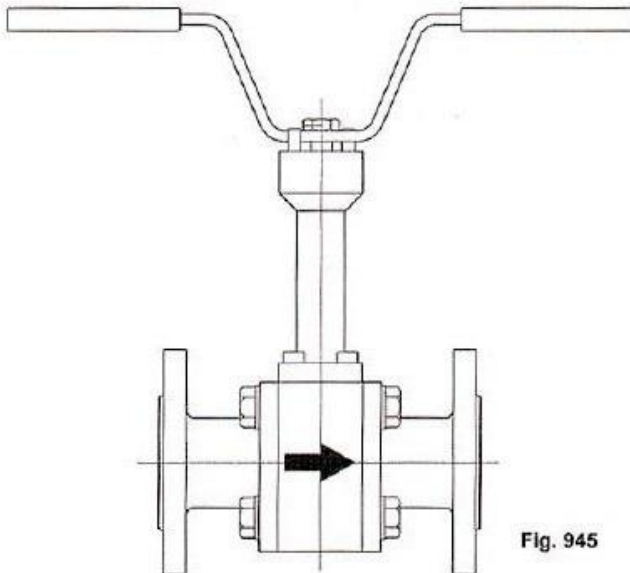

Fig. 945